

⚠ ATTENTION: PLEASE READ ALL INSTRUCTIONS BEFORE ASSEMBLING/INSTALLING THIS PRODUCT

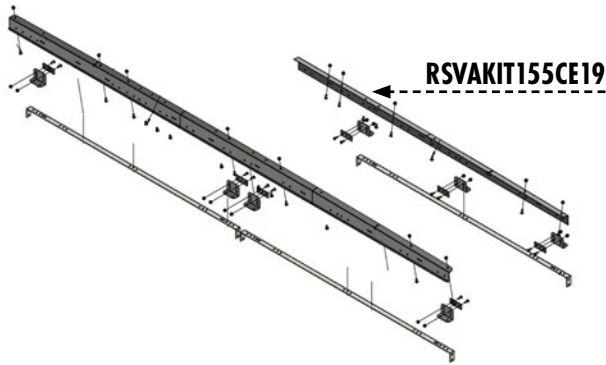

⚠ WARNING

ANY ALTERATIONS, UNINTENDED OR UNAPPROVED WORK/USE OF THIS PRODUCT COULD CREATE A HAZARDOUS CONDITION THAT CAN CAUSE DEATH, PERSONAL INJURY OR PROPERTY DAMAGE.

BEFORE YOU BEGIN:

- THE AVERAGE EXPECTED INSTALL TIME FOR THIS PRODUCT IS 70 MINUTES
- READ ALL THE INSTRUCTIONS BEFORE ASSEMBLY & INSTALLATION
- ENSURE YOU HAVE SOME ASSISTANCE FROM A SECOND PERSON TO AVOID VEHICLE DAMAGE OR ANY PERSONAL INJURY
- BE AWARE ON THE LOCATION OF VEHICLE WIRING, GAS TANKS, GAS LINES, BRAKE LINES, & ANY OTHER IMPORTANT ITEMS
- ENSURE IT IS SAFE BEFORE DRILLING OR CUTTING ANYWHERE ON THE VEHICLE & INSTALLING ANY OF OUR PRODUCTS
- CONFIRM YOU HAVE ALL THE NECESSARY PARTS, TOOLS, EQUIPMENT, & TIME REQUIRED BEFORE COMMENCING

PART No. RSVAKIT155CE19 suits the following vehicles:

- 1997-2014 Chevrolet Express 1500, 155" W/B
- 1997-2021 Chevrolet Express 1500, 155" W/B
- 1997-2021 Chevrolet Express 3500, 155" W/B
- 1997-2014 GMC Savana 1500, 155" W/B
- 1997-2021 GMC Savana 2500, 155" W/B
- 1997-2021 GMC Savana 3500, 155" W/B

TOOLS REQUIRED:



⚠ ATTENTION

IMAGES USED IN THIS GUIDE MAY VARY SLIGHTLY DEPENDING ON YOUR MODEL

The RolaCase Roof Anchor Kit for the Chevy Express (Part#: RSVAKIT155CE19) is made up of the following parts that need to be located and assembled together with the hardware provided:

The RolaCase Floor Anchor Kit for the Chevy Express (Part#: RSVAKIT155CE19) is made up of the following parts that need to be located and assembled together with the hardware provided:

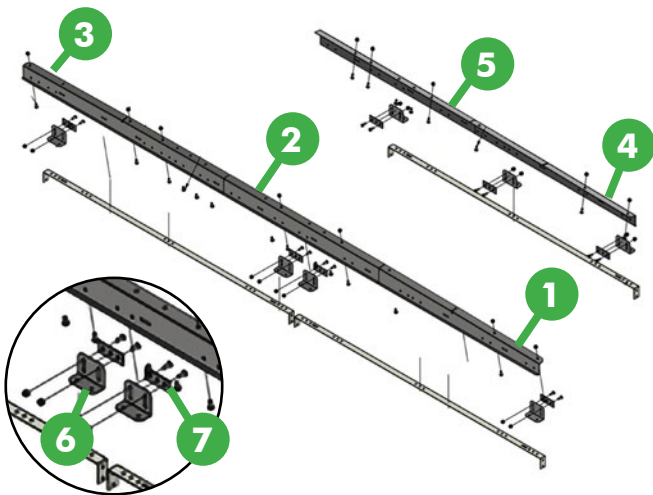

ROOF ANCHORS

1. Drivers side (LH) rear roof anchor
2. Drivers side (LH) middle roof anchor
3. Drivers side (LH) front roof anchor
4. Passenger side (RH) rear roof anchor
5. Passenger side (RH) middle roof anchor
6. Height adjustable angle plates
7. Clamp plates
8. All necessary roof hardware - refer to next page

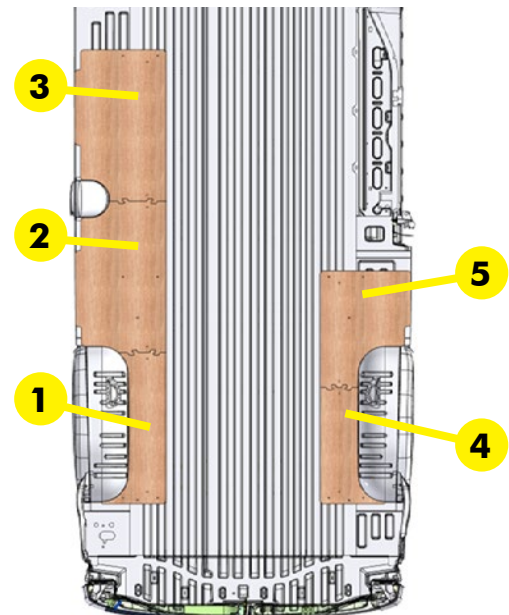

FLOOR ANCHORS

1. Drivers side (LH) rear floor anchor
2. Drivers side (LH) middle floor anchor
3. Drivers side (LH) front floor anchor
4. Passenger side (RH) rear floor anchor
5. Passenger side (RH) middle floor anchor
6. All necessary floor hardware- refer to floor section

⚠ ATTENTION: PLEASE READ ALL INSTRUCTIONS BEFORE ASSEMBLING/INSTALLING THIS PRODUCT

⚠ WARNING

ANY ALTERATIONS, UNINTENDED OR UNAPPROVED WORK/USE OF THIS PRODUCT COULD CREATE A HAZARDOUS CONDITION THAT CAN CAUSE DEATH, PERSONAL INJURY OR PROPERTY DAMAGE.

⚠ ATTENTION

IMAGES USED IN THIS GUIDE MAY VARY SLIGHTLY DEPENDING ON YOUR MODEL

SECTION 1 - ROOF ANCHOR NUTS AND BOLTS



HEIGHT ADJUSTABLE
 ANGLE PLATES

8x
 QUANTITY



CLAMP PLATES

8x
 QUANTITY



NYLOC NUT

16x
 QUANTITY
 SIZE 1/4"

12x
 QUANTITY
 SIZE M6"



SPRING WASHER

11x
 QUANTITY



PAN PHILLIPS BOLTS

16x
 QUANTITY
 SIZE 1/4"x5/8"

23x
 QUANTITY
 SIZE M6x20"

HARDWARE INCLUSIONS	QUANTITY
HEIGHT ADJUST ANGLES	8
CLAMP PLATE	8
PAN PHIL BOLT 1/4"x5/8" (16mm)	16
PAN PHIL BOLT M6x20mm	23
NYLOC NUT 1/4"	16
SPRING WASHER 1/4"	11
NUTS M6	12
CABLE TIES - 300mm	8

A Remove the Left-Hand upper plastic trim near the driver's seat headrest, you will not need to replace this item and it is no longer required. You have the option to modify and cut this trim to suit if you wish to reinstall.



B Release the driver's side upper black wiring harness that is affixed along the whole length of the L/H inner roof rail body, you may need to pry some clips off to get this done

C Locate the box that contains the set of Rolacase Chevy Express Roof Anchors and open it, there should be FIVE long metal sections, THREE for the Left, TWO for the Right, & a bag of supporting brackets, nuts, bolts, & washers for each side

D Begin by affixing the RH rear passenger side roof anchor bracket supplied to the rear of the RH inner roof rail of the vehicle using the supplied nuts, bolts and washers. This rear bracket will affix to the vehicle via some OEM mounting points of the roof rail that have a welded thread to accept the M6 x 20 bolts and spring washers supplied. Refer to image below:

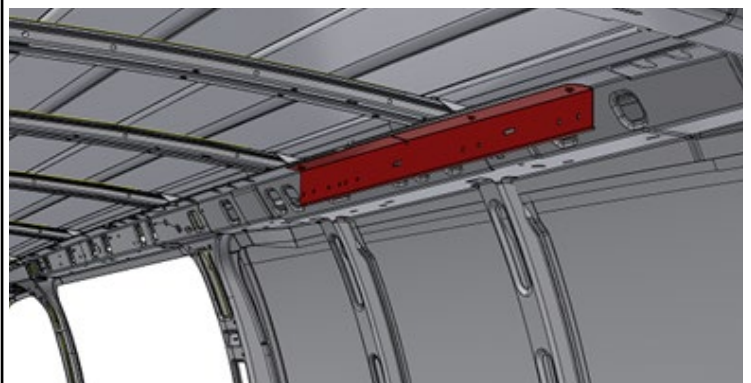

RH / PASSENGER'S SIDE

⚠ ATTENTION: PLEASE READ ALL INSTRUCTIONS BEFORE ASSEMBLING/INSTALLING THIS PRODUCT

⚠ WARNING

ANY ALTERATIONS, UNINTENDED OR UNAPPROVED WORK/USE OF THIS PRODUCT COULD CREATE A HAZARDOUS CONDITION THAT CAN CAUSE DEATH, PERSONAL INJURY OR PROPERTY DAMAGE.

E Affix the RH middle passenger side roof anchor bracket supplied to the middle of the RH inner roof rail of the vehicle using the nuts, bolts and washers supplied. This middle bracket will affix to the vehicle via some OEM mounting points of the roof rail that have a welded thread to accept the M6 x 20 supplied bolts and spring washers. Note that some of the holes do not have a welded nut on the body and you will be required to insert an M6 Nyloc nut at the end of the M6 x 20 bolts to complete the operation. Refer to image below:

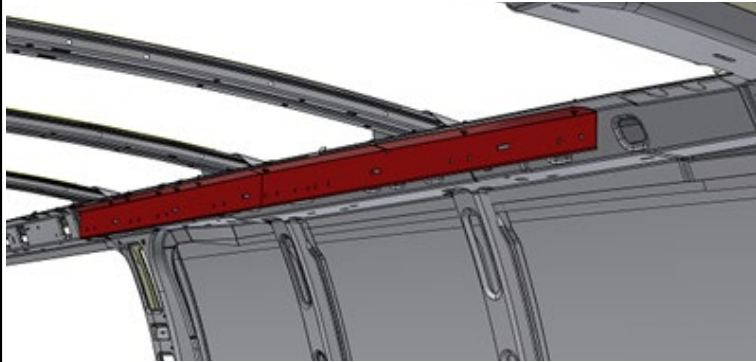

RH / PASSENGER'S SIDE

F You will need to carefully drill TWO holes at the rear furthest points and use the M6 x 20 bolt and M6 Nyloc nut supplied to complete this operation. Refer to images below:

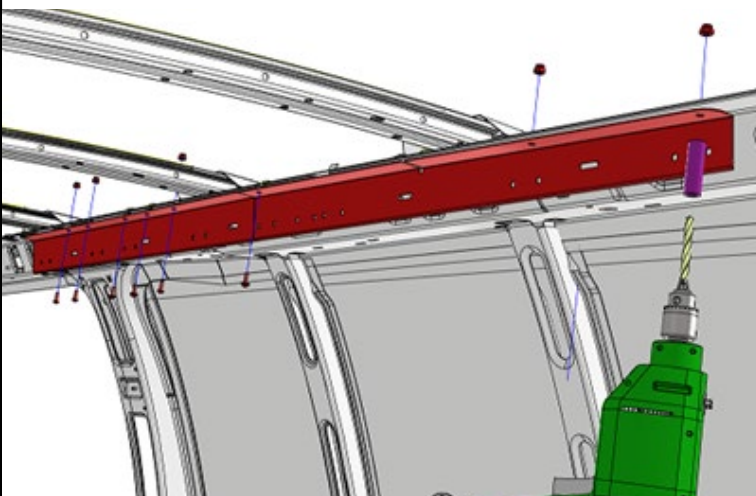

RH / PASSENGER'S SIDE

G Secure the THREE remaining LH upper anchor brackets supplied to the inner roof rail of the vehicle with the same methodology used on the RH side using the nuts, bolts, and washers supplied. The Front, Middle and Rear brackets will affix to the vehicle via some of the OEM mounting points on the roof rail that have a welded thread to accept the supplied bolts. Again, you will need to carefully drill TWO holes at the rear furthest points and use a supplied nut & bolt to complete this operation. Refer to image below:

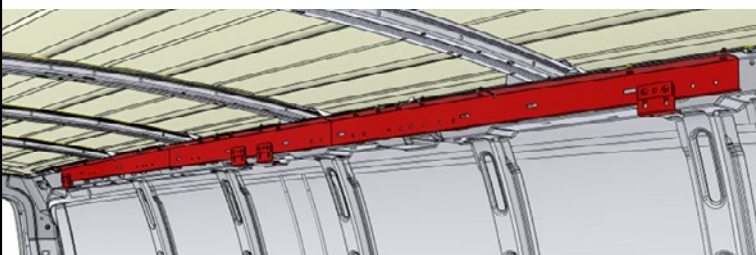

LH / DRIVER'S SIDE

⚠ ATTENTION

IMAGES USED IN THIS GUIDE MAY VARY SLIGHTLY DEPENDING ON YOUR MODEL

H Use the supplied cable ties to re-affix the Left-Hand upper black wiring harness that was released in previous step. There are slots that have been cut out on the whole length of the L/H upper anchor brackets to allow for feeding through of cable ties to secure this harness.

I Now that both the LH and RH roof anchors have been secured to the vehicle, it is now time to affix the height adjuster clamps to the anchors. Please note that you should have ONE leftover height adjuster clamp that has been provided to support alternative shelving

NOTE ADJUSTABLE 'L' BRACKET FACING THIS WAY WHEN INSTALLED

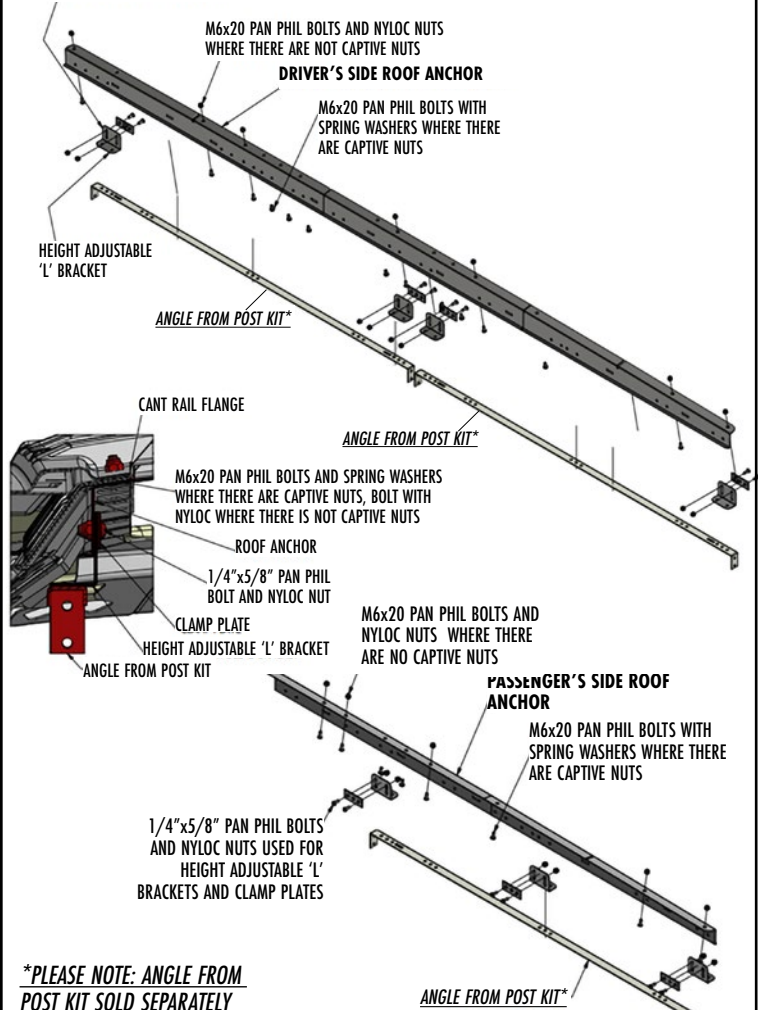

FOR A BIGGER IMAGE PLEASE GO TO THE LAST PAGE OF THIS GUIDE

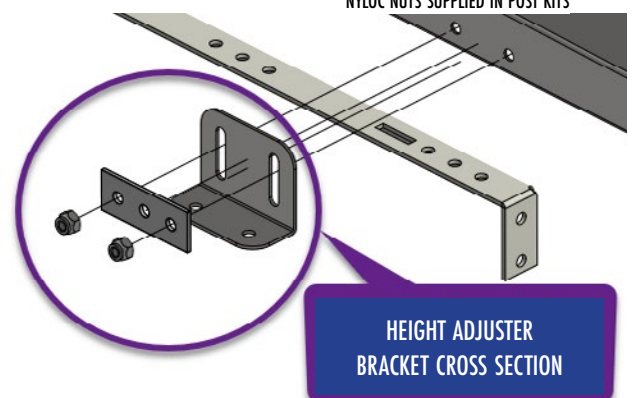

HEIGHT ADJUSTER BRACKET CROSS SECTION

⚠ ATTENTION: PLEASE READ ALL INSTRUCTIONS BEFORE ASSEMBLING/INSTALLING THIS PRODUCT



⚠ WARNING

ANY ALTERATIONS, UNINTENDED OR UNAPPROVED WORK/USE OF THIS PRODUCT COULD CREATE A HAZARDOUS CONDITION THAT CAN CAUSE DEATH, PERSONAL INJURY OR PROPERTY DAMAGE.

⚠ ATTENTION

IMAGES USED IN THIS GUIDE MAY VARY SLIGHTLY DEPENDING ON YOUR MODEL

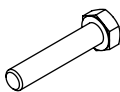
SECTION 2 - FLOOR ANCHOR BRACKETS

	10x QUANTITY
HEX BOLT	
	10x QUANTITY
WASHER	
	10x QUANTITY
RIVET NUT	

HARDWARE INCLUSIONS	QUANTITY
WASHERS M8	10
HEX BOLT M8x40mm	10
RIVET NUTS M8	10

A To secure the floor anchors properly, you will need to remove the factory liner. Starting from the rear of the van, lift up and roll back the OEM floor lining towards the front and remove out of the vehicle

B Using a T-50 torx, remove two OEM floor "Cargo Tie Downs" (otherwise known as "D shackles") on the L/H side of the vehicle marked as reference point (2) & (3) but not including reference point (1) just behind the drivers' seat as per image below:

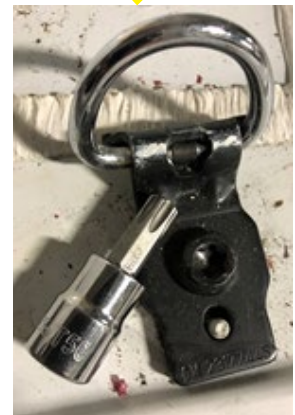
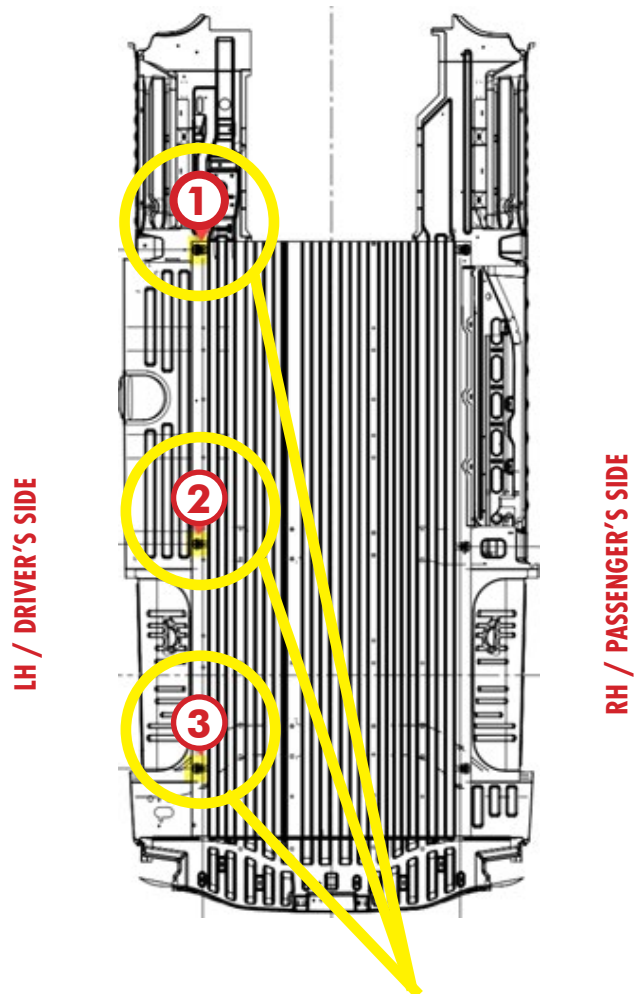



⚠ ATTENTION: PLEASE READ ALL INSTRUCTIONS BEFORE ASSEMBLING/INSTALLING THIS PRODUCT

⚠ WARNING

ANY ALTERATIONS, UNINTENDED OR UNAPPROVED WORK/USE OF THIS PRODUCT COULD CREATE A HAZARDOUS CONDITION THAT CAN CAUSE DEATH, PERSONAL INJURY OR PROPERTY DAMAGE.

C Using a T-50 torx, remove a single OEM floor "Cargo Tie Downs" on the R/H side of the vehicle marked as reference point (4) and reference point (5) near the side door opening as per image below.

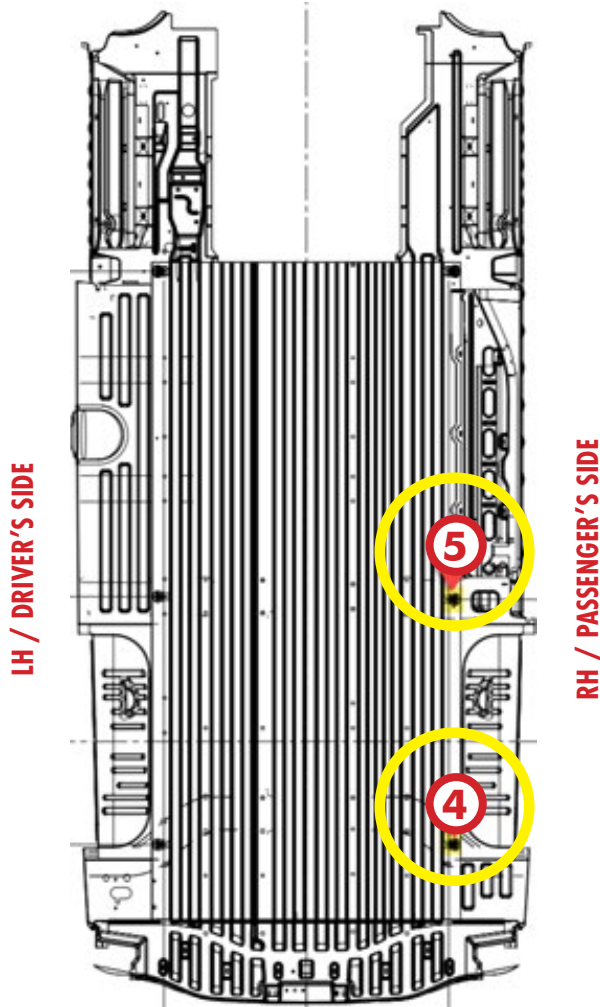

D Locate the box that contains the set of Rolacase Chevy Express 155" Floor Anchors plates, open it and identify the three L/H wooden floor plates. Position the three plates into their correct positions and secure them together by connecting the "jigsaw" pattern to make one larger plate. Refer to the image below:

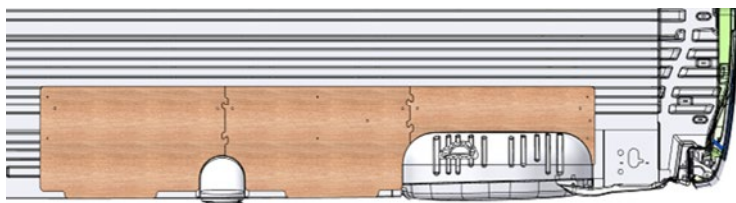

⚠ ATTENTION

IMAGES USED IN THIS GUIDE MAY VARY SLIGHTLY DEPENDING ON YOUR MODEL

E Place the assembled Left-Hand lower floor anchor into the correct position by ensuring it fits tight up against the wheel arch cut-outs and the wall of the van

F There are TWO pilot holes per wooden piece have been pre-drilled in this L/H floor anchor assembly. With the floor plate in the correct position, mark out the points on the OEM floor by using a marker pen through the holes on the wooden floor. You should be marking out 6 positions to drill in the next steps. Note that some of the holes have a metal "T-Nut" in them, these are not the holes you will be using to secure to the floor.

G Move the wooden floor section out of the way and drill through the OEM floor where you marked in the previous step and secure the 6 rivet nuts supplied into position. A drill bit to match the rivet nuts must be used.

H Re-position the wooden floor anchor and secure to the floor via 6 bolts and washers provided (2 per piece)

I Locate the remaining two R/H wooden floor plates. Position them into their correct positions and secure them together by connecting the "jigsaw" pattern to make one larger plate. Refer to the image below:

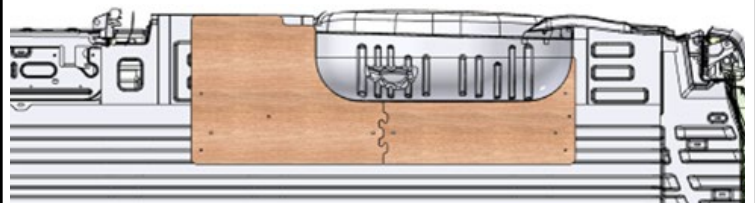

J Place the assembled Right-Hand lower floor anchor into the correct position by ensuring it fits tight up against the wheel arch cut-outs and the wall of the van

K There are TWO pilot holes per wooden piece have been pre-drilled in this R/H floor anchor assembly. With the floor plate in the correct position, mark out the points on the OEM floor by using a marker pen through the holes on the wooden floor. You should be marking out 6 positions to drill in the next steps. Note that some of the holes have a metal "T-Nut" in them, these are not the holes you will be using to secure to the floor.

L Move the wooden floor section out of the way and drill through the OEM floor where you marked in the previous step and secure the 4 rivet nuts supplied into position. A drill bit to match the rivet nuts must be used

M Re-position the wooden floor anchor and secure to the floor via 4 bolts and washers provided (2 per piece)

⚠ ATTENTION: PLEASE READ ALL INSTRUCTIONS BEFORE ASSEMBLING/INSTALLING THIS PRODUCT

⚠ WARNING

ANY ALTERATIONS, UNINTENDED OR UNAPPROVED WORK/USE OF THIS PRODUCT COULD CREATE A HAZARDOUS CONDITION THAT CAN CAUSE DEATH, PERSONAL INJURY OR PROPERTY DAMAGE.

⚠ ATTENTION

IMAGES USED IN THIS GUIDE MAY VARY SLIGHTLY DEPENDING ON YOUR MODEL

N Correct assembly of the wooden floor anchor plates should appear as per image below:

PARTITION

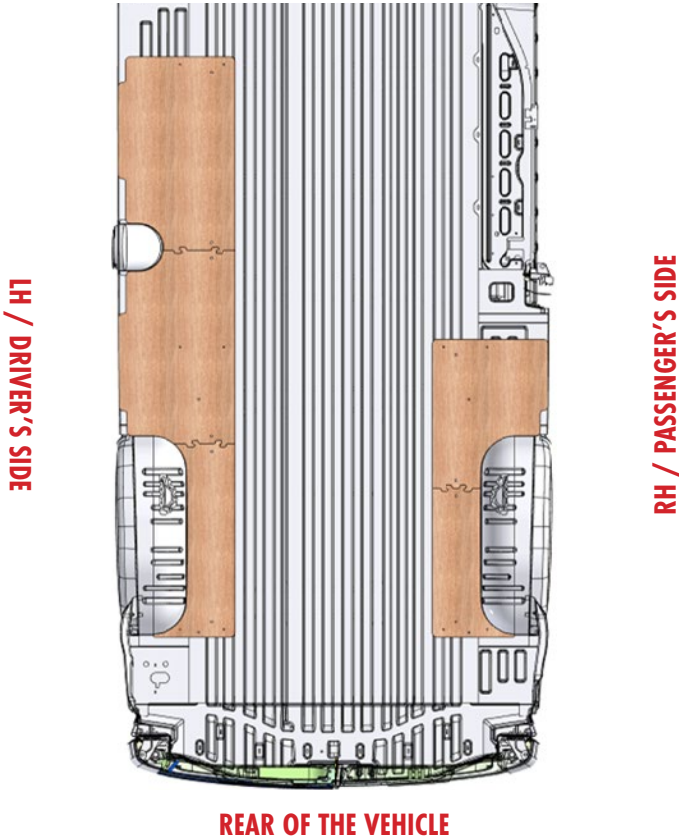

O At this stage, the floor anchor installation is complete and you have the following options:

Reinstall the factory OEM floor liner with some simple modifications. Starting from the front of the van near the cabin, insert the rolled up floor liner removed at the beginning and roll it back towards the rear of the vehicle so that the van floor liner is in the factory position. Using a Stanley knife, carefully cut the liner around the wooden floor anchors and discard the sections that would otherwise sit on top of the floor anchor plates.

Reinstall some of the OEM shackles that were removed in previous steps as we have pre-drilled the holes in the wooden floor anchors to allow for this option, however, we recommend a longer bolt and spacers to complete this option correctly (not supplied). We do not recommend you fit the Left Rear or Right Rear shackles as it may interfere with our shelving posts.

P The vehicle specific Roof & Floor anchor installation is now complete, go back through and tighten all bolts securing the anchor assembly to the vehicle

This concludes the installation process, please go through and double check that all the nuts and bolts are tight. **If you need further clarity and prefer to watch a video of the process, please visit our YouTube Channel or our Support Page on our website www.rolacase.com** You are now ready to install your posts, please refer to your posts instructions

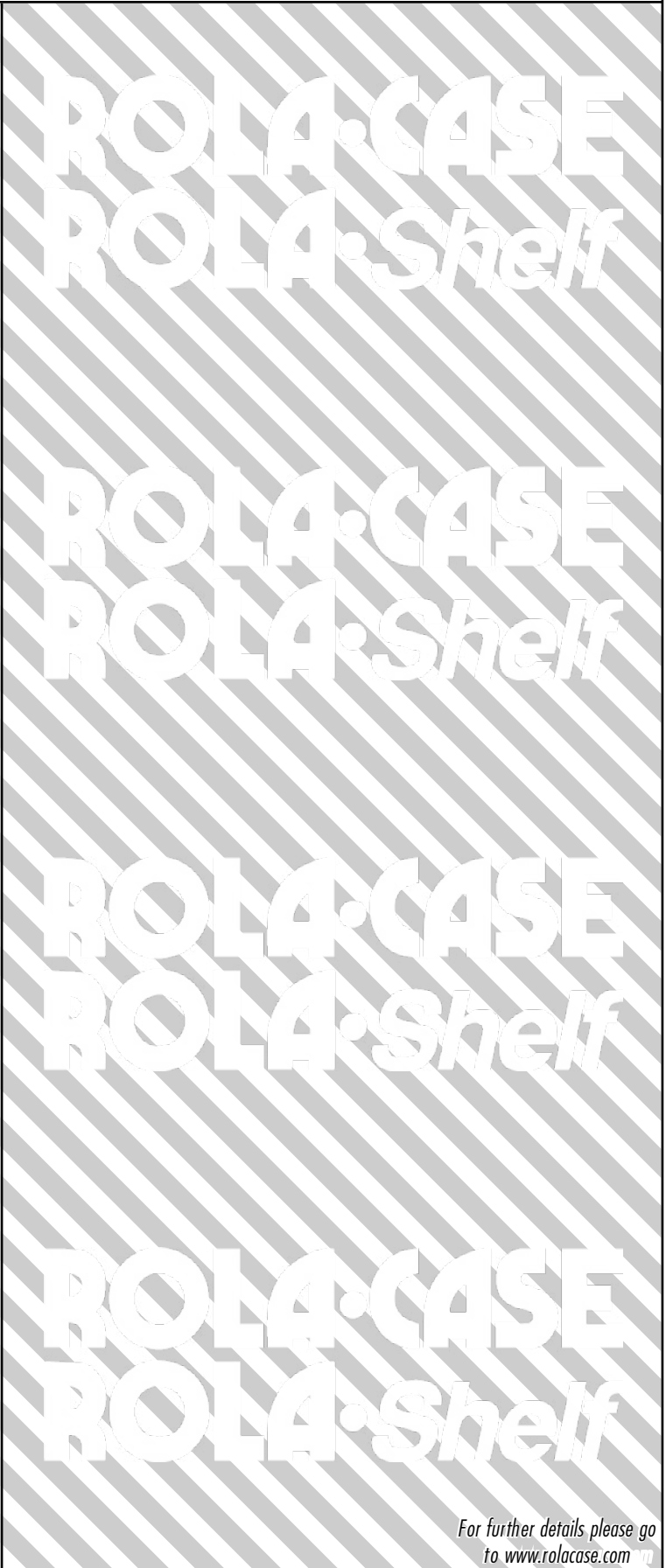

For further details please go to www.rolacase.com

M6x20 PAN PHIL BOLTS AND NYLOC NUTS WHERE THERE ARE NO CAPTIVE NUTS

PASSENGER'S SIDE ROOF ANCHOR

M6x20 PAN PHIL BOLTS WITH SPRING WASHERS WHERE THERE ARE CAPTIVE NUTS

ANGLE FROM POST KIT*

HEIGHT ADJUSTABLE 'L' BRACKET BOLTED TO TOP ANGLE USING 1/4" x 5/8" PAN PHIL BOLTS AND NYLOC NUTS SUPPLIED IN POST KITS

NOTE:
NUMBER OF HEIGHT ADJUSTABLE 'L' BRACKETS MAY VARY DEPENDING ON YOUR POST KIT LAYOUT

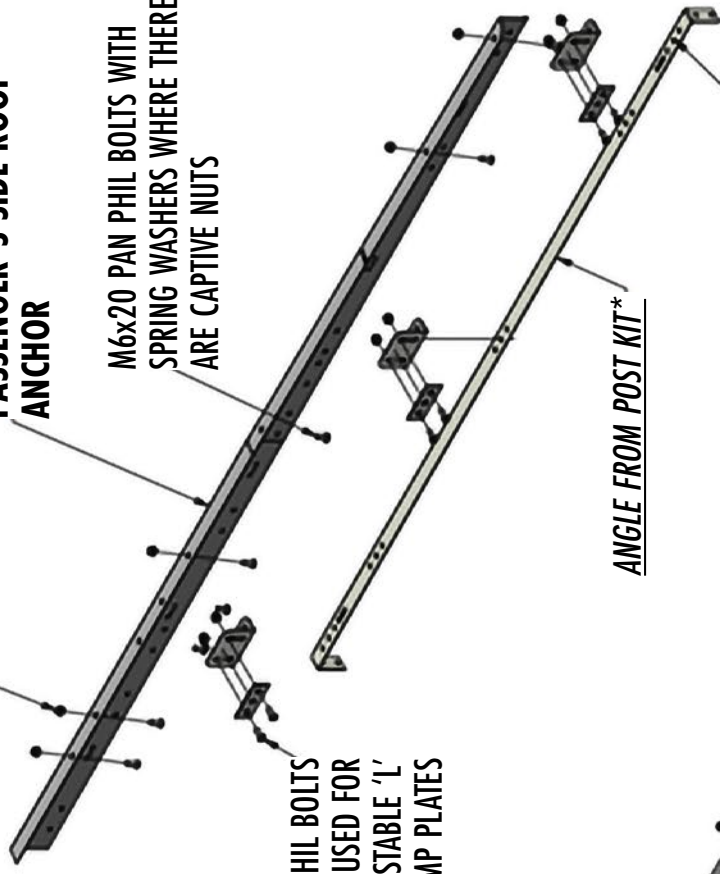

1/4" x 5/8" PAN PHIL BOLTS AND NYLOC NUTS USED FOR HEIGHT ADJUSTABLE 'L' BRACKETS AND CLAMP PLATES

NOTE ADJUSTABLE 'L' BRACKET FACING THIS WAY WHEN INSTALLED

M6x20 PAN PHIL BOLTS AND NYLOC NUTS WHERE THERE ARE NOT CAPTIVE NUTS

DRIVER'S SIDE ROOF ANCHOR

M6x20 PAN PHIL BOLTS WITH SPRING WASHERS WHERE THERE ARE CAPTIVE NUTS

ANGLE FROM POST KIT*

ANGLE FROM POST KIT*

M6x20 PAN PHIL BOLTS AND SPRING WASHERS WHERE THERE ARE CAPTIVE NUTS, BOLT WITH NYLOC WHERE THERE IS NOT CAPTIVE NUTS

*PLEASE NOTE: ANGLE FROM POST KIT SOLD SEPARATELY

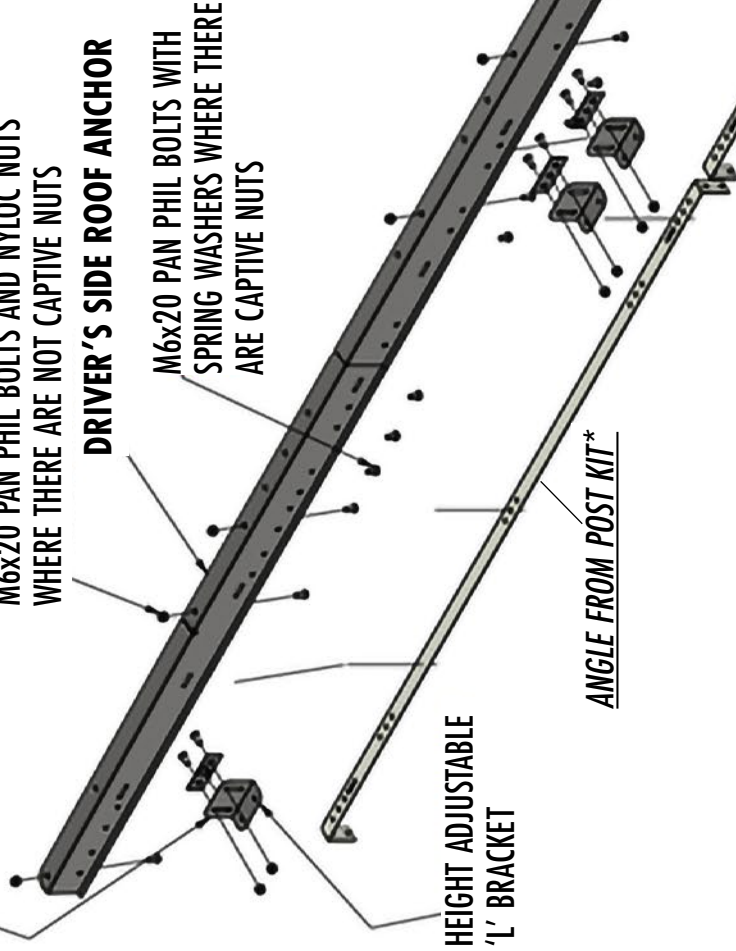

HEIGHT ADJUSTABLE 'L' BRACKET

CANT RAIL FLANGE

M6x20 PAN PHIL BOLTS AND SPRING WASHERS WHERE THERE ARE CAPTIVE NUTS, BOLT WITH NYLOC WHERE THERE IS NOT CAPTIVE NUTS

ROOF ANCHOR

1/4" x 5/8" PAN PHIL BOLT AND NYLOC NUT

CLAMP PLATE

HEIGHT ADJUSTABLE 'L' BRACKET ANGLE FROM POST KIT

