

**⚠ ATTENTION: PLEASE READ ALL INSTRUCTIONS BEFORE ASSEMBLING/INSTALLING THIS PRODUCT**

**INCLUSIONS:**

2 RSPEP-TOP HAT

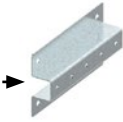

2 PAN PHIL BOLTS



2 SELF TAPPING SCREWS



2 NYLOC NUTS



12 SCREWS



1 RSPEP/MDRF/

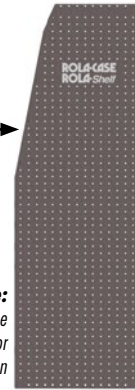

*Please note:  
end panels come  
in either a left or  
right option*

**⚠ WARNING**

ANY ALTERATIONS, UNINTENDED OR UNAPPROVED WORK/USE OF THIS PRODUCT COULD CREATE A HAZARDOUS CONDITION THAT CAN CAUSE DEATH, PERSONAL INJURY OR PROPERTY DAMAGE.

**BEFORE YOU BEGIN:**

- THE AVERAGE EXPECTED INSTALL TIME FOR THIS PRODUCT IS 10 MINUTES
- READ ALL THE INSTRUCTIONS BEFORE ASSEMBLY & INSTALLATION
- ALWAYS WEAR APPROPRIATE PERSONAL PROTECTIVE EQUIPMENT, ESPECIALLY EYEWEAR WHEN INSTALLING OUR PRODUCTS
- CONFIRM YOU HAVE ALL THE NECESSARY PARTS, TOOLS, EQUIPMENT, & TIME REQUIRED BEFORE COMMENCING

**PART No. RSPEP/ - comes in 2 options:**

- RSPEP/MDRF/R - Right Mid End Panel
- RSPEP/MDRF/L - Left Mid End Panel

*\*Ideal for Mid/High Roof Vans*

**⚠ ATTENTION**

All RolaCase/RolaShelf shelving products are to be used exclusively and in conjunction with RolaCase and RolaShelf shelving bays only. Failure to do so will cause the shelving/products to perform in a nonfunctional manner and will void your warranty

**TOOLS REQUIRED:**



Screw Drivers



Cordless Drill with Torque settings

**⚠ ATTENTION**

IMAGES USED IN THIS GUIDE MAY VARY SLIGHTLY DEPENDING ON YOUR MODEL

The RolaCase Mid Roof End Panel comes in 2 different options:

RSPEP/MDRF/L (MID-LEFT END PANEL)

RSPEP/MDRF/R (MID-RIGHT END PANEL)



18.1"

*Ideal for Driver's side Rear*

56.85"



18.1"

*Ideal for Passenger's side Rear*

**REFER TO NEXT PAGE FOR FURTHER INSTRUCTIONS**



Left and Right Mid Roof End Panels on a Ford Transit



**⚠ ATTENTION: PLEASE READ ALL INSTRUCTIONS BEFORE ASSEMBLING/INSTALLING THIS PRODUCT**

**⚠ WARNING**

ANY ALTERATIONS, UNINTENDED OR UNAPPROVED WORK/USE OF THIS PRODUCT COULD CREATE A HAZARDOUS CONDITION THAT CAN CAUSE DEATH, PERSONAL INJURY OR PROPERTY DAMAGE.

- A** Begin by making sure you have the right end panel to suit your vehicle and application
- B** Ensure your frames are installed and secured before proceeding
- C** Secure screws as illustrated on the next images

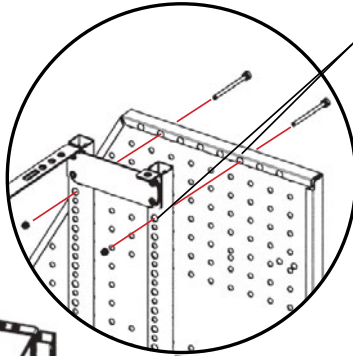

**Tip** by default we recommend aligning the 3rd hole of the End Panel with the 3rd hole of the posts. Please note: this may not be feasible in some vehicles, if this is the case it is acceptable to use neighbouring holes

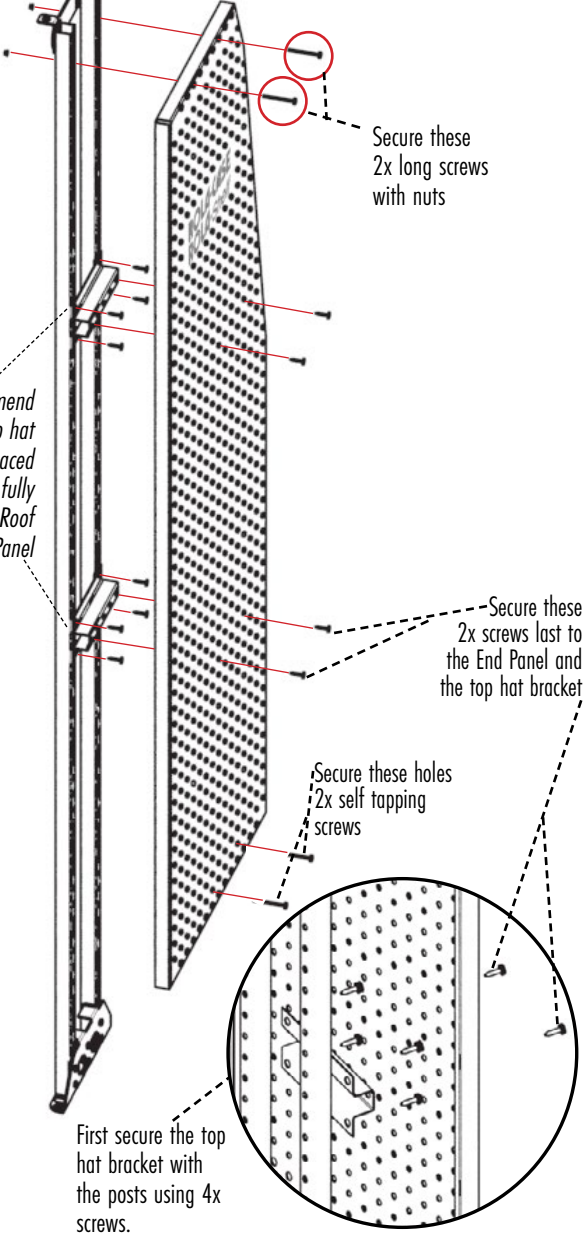

**Tip** we recommend that the the 2 top hat brackets are spaced out equally to fully support the Mid Roof End Panel

**⚠ ATTENTION**

IMAGES USED IN THIS GUIDE MAY VARY SLIGHTLY DEPENDING ON YOUR MODEL

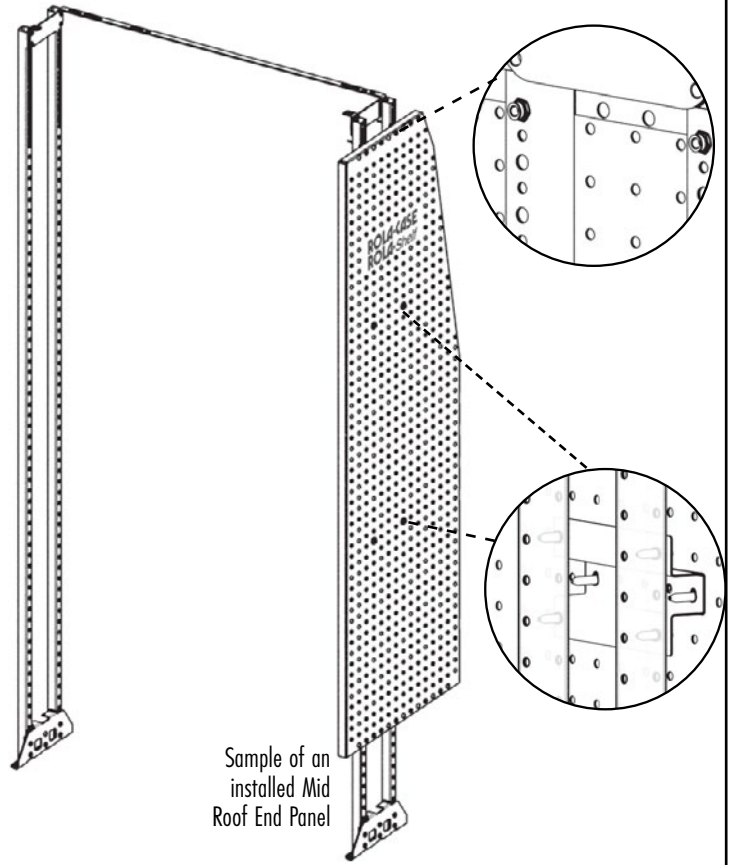

For further details please go to [www.rolacase.com](http://www.rolacase.com)